

MONTESSORI COMMUNITY SCHOOL PERSPECTIVES



**2020-2021
ANNUAL
REPORT**



**EDUCATION
FOR LIFE**

MESSAGE FROM HEAD OF SCHOOL & BOARD PRESIDENT

Dear Friends of MCS -

Thank you for your generous support of Montessori Community School (MCS). In spite of a historic pandemic that has touched the lives of every individual and community on the planet, MCS is thriving! During this extraordinary era of Covid-19, our overarching goal has been to ensure continuity and remain true to our foundational mission to provide an excellent Montessori educational experience. We have listened to the voices of our staff, our families, and experts in public health, to design protocols and practices that are aligned with our core values and principles and have made it possible for our students to remain actively engaged, enjoying shared experiences, and growing and learning every day! We have rolled with the punches to successfully meet the greatest challenge of our time, and we couldn't be more proud of the talented and committed MCS staff, Board of Trustees, parents, and family of supporters that have come together to take care of our keiki.

In addition to creating a safe and healthy physical environment, Kylie Dunn, School Counselor, has led our work in supporting the social and emotional wellbeing of MCS ohana. Kylie began the 2020-2021 academic year by educating staff on the benefits of utilizing a trauma-informed approach, and continues to provide teachers and parents with evidence-based strategies to promote student success and happiness. Students receive emotional counseling as needed, social guidance, and lessons designed to facilitate confidence and resilience. Our MCS community has exhibited an incredible degree of collaboration and kindness in creating a safe space for all.

In this issue of Perspectives, you will see how your gift to MCS makes a difference in the lives of our students and staff. We hear, again and again, that our students, like Ian Delse, leave MCS as self-starters, equipped with skills and knowledge, and the aspiration of contributing to their communities.



Your generosity makes possible exemplary opportunities that empower and inspire the next generation of scientists, artists, writers, geologists, and geographers.

You will also read about Bob Sisson, or “Mr. Bob”, a former parent and board president, and current Computer & Coding teacher among our Elementary Specialists, as well as his daughter Alex Sisson, an alumnus and recipient of the Jerry Mueller Montessori Teacher Training Fund that supports staff in achieving an American Montessori Society (AMS) teacher certificate. It is so gratifying to see Jerry's spirit living on through the fund he started which you help to sustain. This is truly a full-circle MCS legacy story!

As the only accredited Pre-6th grade Montessori school on Oahu, we thank you, parents, grandparents, staff members, and alumni for partnering with us to provide, as Dr. Montessori said, an education for life!

Mahalo nui loa for all that you do!

Marjie & Todd,

Marjie Carroll
Head of School

Todd Iacovelli
MCS Board President

MESSAGE FROM THE DIRECTOR OF DEVELOPMENT

As the new Director of Development, I look forward to partnering with you to enhance Montessori Community School's (MCS) strengths and innovate for the future. Fatherhood has taught me that there is nothing more important than helping our children develop a lifelong passion for learning and providing them with opportunities to maximize their potential. In only three months, I've experienced, first hand, how generous all of you are. This is what you helped us to accomplish during the 2020-2021 school year:

- Our Children's Education Fund, which includes proceeds from this year's Virtual Fun Run, helped provide over \$50,000 of financial aid to 23 students, or 14% of enrollment.
- Over \$6,800 was given in support of the Jerry Mueller Teacher Training Fund. To date, this fund has provided nearly \$30,000 to MCS teachers working on their Montessori certification. This year's recipient was Ms. Sheryl Lomongo, Preschool & Kindergarten teacher.
- Foodland's *Give Aloha* program, raised over \$10,000 to provide professional development opportunities for our teachers. Ms. Monika Day, an Upper Elementary teacher, attended a National Geographic workshop, giving her new resources to help her students develop a passion for exploring the world.

Your donations really make a difference to MCS, especially for our students and teachers! We couldn't accomplish all that we do without your help!



Owen Gaillard with his Fun Run prize



Ms. Sheryl, Preschool & Kindergarten teacher



Ms. Monika with her students



James Kia

James Kia
Director of Development

GRACE, RESILIENCY, COURAGE, COMMUNITY - THE MAGIC OF MCS

Jennifer Oyer is a guest contributor and served as the interim Director of Development from March 2020 – December 2021.

When I was a young girl – some 33 years ago (but who’s counting) – my thirst for lifelong learning began, and I found refuge in the library at Hawaii Baptist Academy, where I got lost in *The Babysitter’s Club* and *Chronicles of Narnia*. Today, that library on Nehoa Street is still a refuge for curious young minds, but now known as the Little House right here at Montessori Community School.

When I stepped back onto that Nehoa campus on March 17, 2020, I knew immediately I was back home — now MCS, rather than Hawaii Baptist Academy from which I graduated — with the roots and tenets focused on all the right things: curious minds, respect for self and others, compassion, and humanity.

What none of us knew in March of 2020 is that those tenets would be tested over the coming months. The entire world shifted quickly, navigating a new Covid reality that sent children home to their screens and away from their friends and classrooms while parents added new and more complicated balls to their daily juggling act. Faculty and staff were thrust into unknown terrain, figuring out how to keep our students and families safe and engaged. And on top of all of that, we were all scared. The unknown is hard. It’s stressful, whether we’re eight years old or 42 years old.



Now, nearly two years later, I’m in awe of MCS’ capacity and ingenuity at all levels – the students, parents, teachers, staff, administration, board, alumni and donors. We hear the words all the time – “everyone stepped up” – and they did. But it’s more than that. In all rights, it should have been chaotic, or stressful or so many other words that denote the severity and difficulties of the challenges we faced. But we didn’t see that at MCS. Instead, we saw grace. We saw patience. We saw ingenuity and creativity and occasional silliness. We saw leadership, and we saw a committed, united team that rowed together without a moment of doubt. We saw community.



That's the magic of MCS. This small but mighty community empowering the next generation of leaders, scientists, writers, artists, and community members. No matter the storm, you equip students with the imagination knowledge, confidence, and courage to reach their highest potential. What a privilege to have been a part of this resilient community where "education for life" is not just a motto, but a firm belief in the stability, strength, and positive impact of Montessori Community School.

Our alumni tell us that they were forged by MCS — that the values, learning styles, time management and intellectual curiosity that guide them today were planted right here on this campus.

Now, two years later, I find myself feeling the same way I did many years ago, only now my aloha goes out to all of you. During my short time here, the grace, patience, and leadership I witnessed is unparalleled in normal times. Yet in these extraordinary times, you did what you do, and the tenets that MCS holds tightly lifted you and this little community during a vicious storm.

In the midst of a global pandemic, political unrest, dire economic times, and fear of the unknown, these values ground MCS. They remind us that we are at our best when we come together, find common ground, listen, and respect one another.

For nearly 50 years, MCS has cultivated hundreds of lifelong learners, empowering them to pursue their interests, develop their strengths, and understand the world so they may choose their place within it.



KYLIE DUNN - THE SCHOOL COUNSELOR WE DIDN'T KNOW WE NEEDED

Sometimes, it's all about timing. Who knew when Kylie Dunn joined the MCS community in 2018 as a substitute teacher after teaching at a Montessori school in Omaha that she'd assist the MCS school administration in laying the groundwork to navigate a pandemic that was looming just over the horizon?

Having developed a keen interest in social and emotional learning as an integral part of a student's education, Kylie returned to school for her counseling credential and graduate training, and then set about creating a counselor position at MCS with the Head of School – an educational leader well-known for her innovation and commitment to teaching the whole child.

When school opened its 2019-2020-year, Kylie Dunn stepped up as School Counselor and Learning Support, a position defined as counseling students, staff, and parents on social, emotional, and academic matters and leading exercises in the classroom to bring social and emotional learning directly into their daily lives.

"Covid threw all of us for a loop," she says, noting that she saw the impact on the entire community right away. "Covid was (and remains) a large-scale trauma and a scary time, wondering how to stay safe when even adults weren't sure. The children were even more in the dark than we were." She quickly saw signs of trauma, anxiety, and even PTSD, and turned to a "trauma informed approach" to navigate the unknown with students, families, and staff.



"Children need to feel safe, supported, and significant," she says, and with Covid, none of that felt guaranteed. Not entirely sure it would work, she turned to mindfulness training, asking the students to lay on the floor and slowly go through body awareness, head to toe. "I watched even our most raucous and squiggly students embrace the techniques and it became meaningful for them," she said, and was thrilled when children and parents reported students were continuing the practice at home with great results. "I tried it at home, and it worked! I felt so much better afterwards," a student excitedly told her.



"Children need to feel safe, supported, and significant."

She also dialed into another unexpected challenge of distance learning. Students are accustomed to mastering a skill at school and then coming home to show their parents. With remote school, children were experiencing the initial failures that come with learning in front of their parents, stressing out parents and students alike. "Parents were coming to me in waves," she says, "seeing behavioral changes in their kids and unsure of what to do."

Everyone was going through the same trauma, and Kylie realized her job was to simply listen, validate, and offer suggestions and assistance. "Often, it's just listening, just being there, offering empathy and understanding. Sometimes, we need a place to just let it all out," she says.

Students and parents validate that it's working. One parent came to Kylie to report that their daughter came home and said simply, "Tell Ms. Kylie the bad things, so only the good things are left in your heart!"

Kylie introduced the Sonia Sotomayor book *Just Ask* to the students, addressing differences and diagnoses, and normalizing these differences in positive ways. A student perked up when Kylie read the story that resonated with him, smiling and raising his hand to say, "That's me!"

For Kylie, it's a calling, meeting students, parents, and staff where they are and making space for their struggles so they can find tools to manage them. "I approach relationships in the community with respect and authenticity, and that same energy comes back to me in return," she says. "With that trust, I collaborate with them, build with them, and heal with them."

Collaborating, building, and healing — exactly the elixir this pandemic demanded, and Ms. Kylie delivered.

MCS PINK TOWER SOCIETY

Throughout the pandemic, generous giving has prevailed and monthly giving programs have sustained organizations across our community with 45% of donors worldwide enrolled in a monthly giving program. In July 2021, MCS launched the Pink Tower Society, our monthly, recurring gifts program.

The Pink Tower Society is a special community of people committed to meeting the greatest needs of the school community every month and who make a long-term commitment to providing program support, financial aid scholarships, and campus enhancements that provide a safe and collaborative learning environment.

Pink Tower Society members receive quarterly progress updates containing stories of impact that your gifts are making for our students, exclusive invitations to “Tea with Marjie” and other special events throughout the year, and recognition in our publications (unless you choose to remain anonymous). We hope that Society members encourage others to support an “education for life.” To learn more about joining this special group, please contact the Development Department at development@montessorihawaii.org.

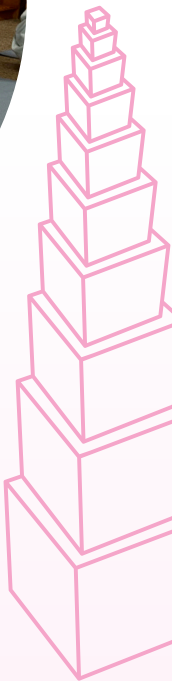

LEGACY & LEADERS CIRCLE

“PAINTING & PETIT FOURS”

Members of MCS’ Legacy and Leaders Circle gathered together for a virtual painting class hosted by Happy Canvas. Each family received a paint set, along with an exclusive dessert gift, delivered right to their front door, and everyone celebrated with their finished memento of the iconic MCS yellow office building.

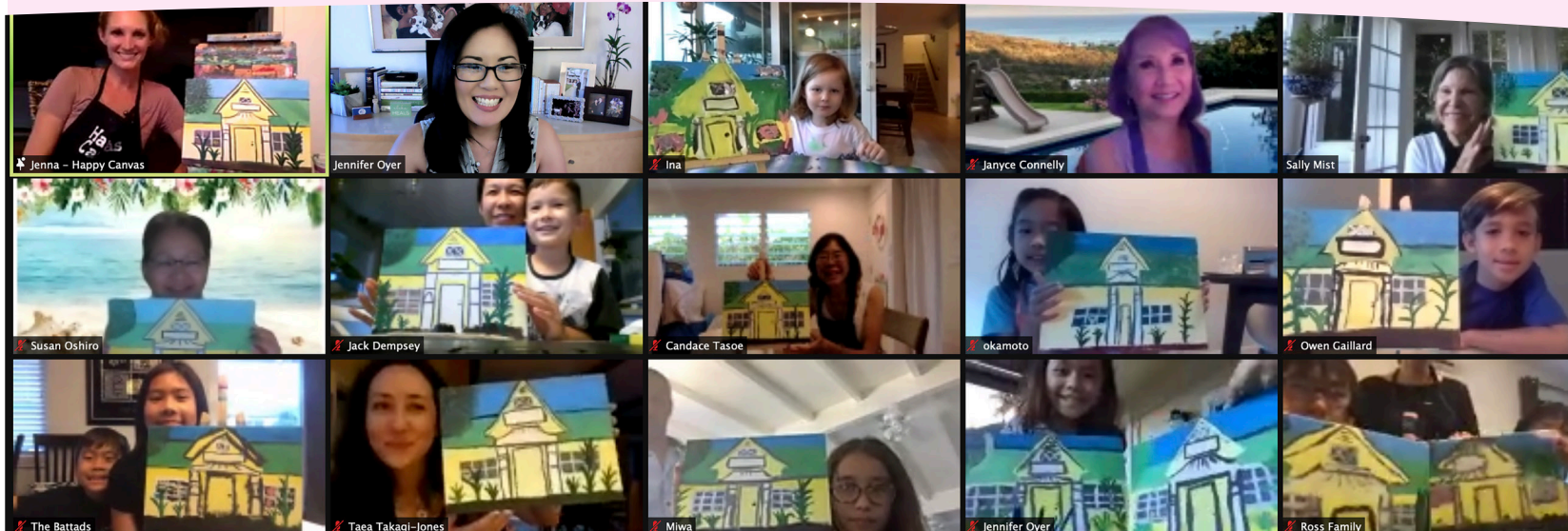

ROBOTS, DRONES, AND SPAGHETTI BRIDGES MR. BOB BRINGS MAGIC TO IT ALL

“Mr. Bob” showed up at MCS some twenty years ago, enrolling his children at the school after becoming a dedicated Montessori parent on the mainland. While his children went on to Iolani School, and then out into the world, he stuck around at MCS, first as a volunteer Math Counts coach, then a couple of stints on the Board (including Board President), and eventually landing on the MCS payroll as the Computer and Coding instructor. Listen to his passion about Montessori, the MCS community, the kids, and the technology he shares with his students, and it’s clear he’d do all of it, and more, with or without the paycheck. It’s in his blood.

Bob Sisson is a man not fond of boredom. Even the mention of it seems vexing to him. Born and raised in Connecticut, Bob headed to college with medicine on the mind, his parents thrilled at the thought of their son, the doctor. When the MCATs dealt a sobering blow, he simply made other plans, joining the Air Force. “While my parents were initially disappointed, their son, the pilot seemed to work, too,” Bob says, laughing.

“I never knew what work was for 16 years, every day flying planes and working with a team to complete our mission,” he says. “And then I got a desk job and understood why people look forward to weekends.” The Air Force brought Bob to Hawaii, and retirement kept him here. “I had to get the fun back, and working with kids brought that back.”

While his work at MCS would keep most people busy, Bob is also the Postmaster at the Manoa Post Office, opening up every morning before heading to school and then swinging back through at the day’s end. Nights and weekends are spent making films and other projects with his extensive Marvel collection and creating new projects, technology lessons, and creative curriculum to further challenge his students.

Bob knows the critical importance of collaboration and problem-solving, first from his Air Force days and now teaching his students. “That’s what goes unnoticed about STEM (science, technology, engineering and mathematics),” he says. “Kids have to work together to accomplish their goal, whether it’s robotics where you have to listen to each other and try different ideas to make it work or tackling projects like the spaghetti bridge challenge and taking each other’s suggestions about how to build that bridge.” (Yes, a spaghetti bridge. And that’s just one of many crazy, fun challenges his students tackle.)

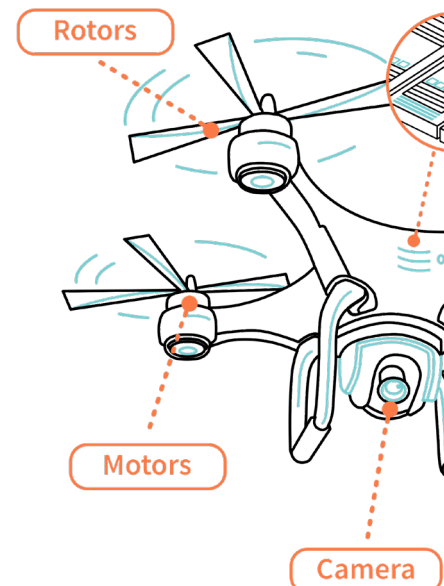

“This school is creating foot soldiers of goodness who go out into the world for the betterment of society.”

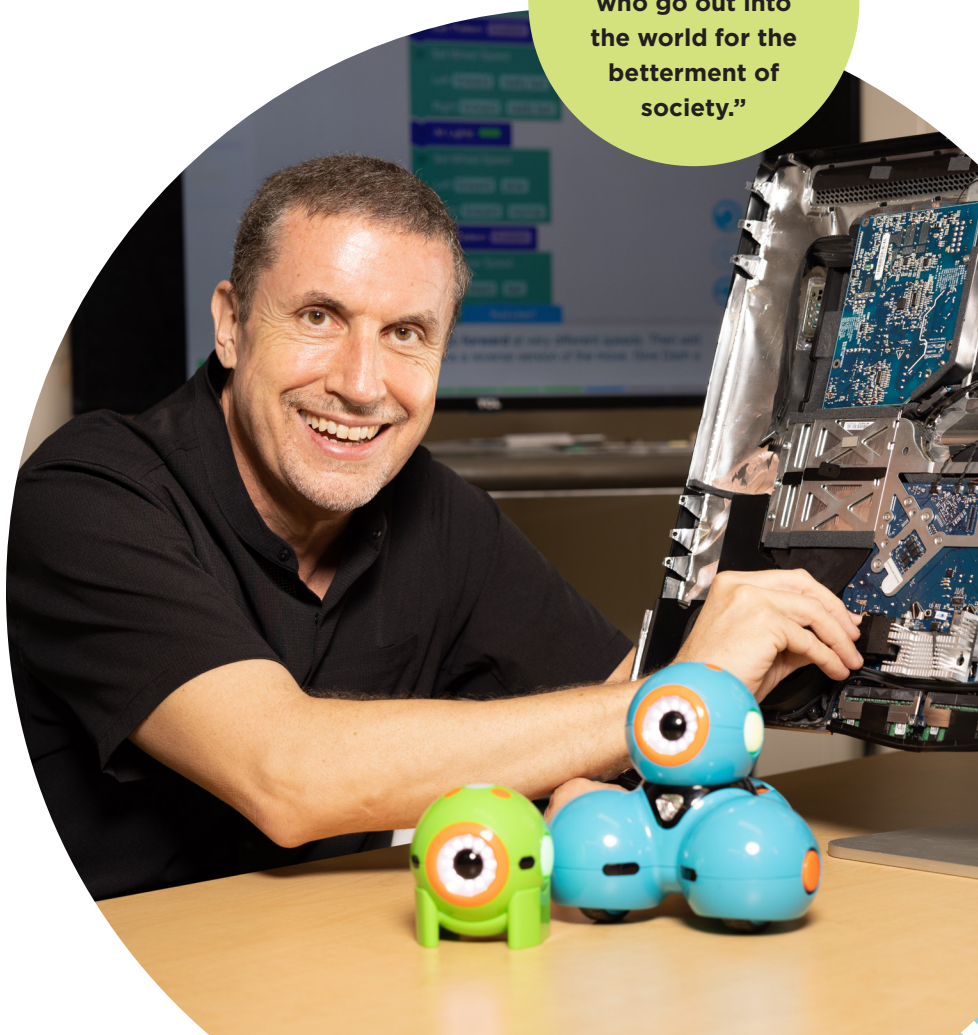

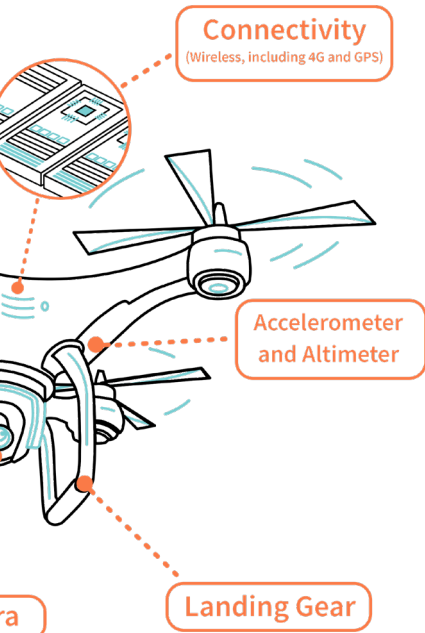
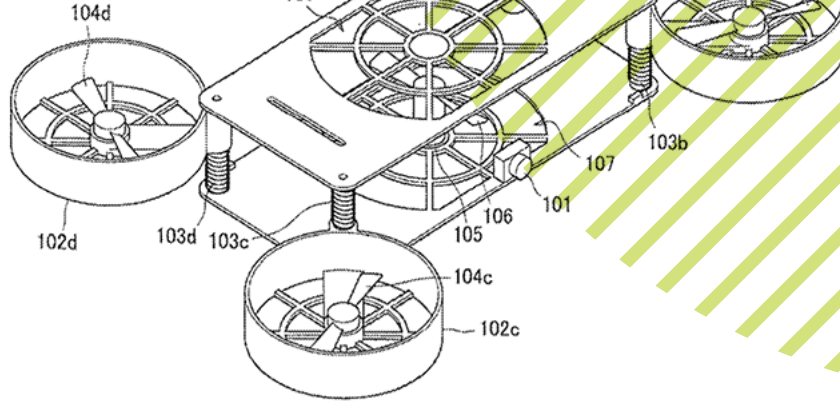

Bob brought his vision into reality when establishing MCS' technology education program, ensuring that students were versed on any platform, spending a year each working on PCs, then Apple laptops, and, finally, tablets. "We're so lucky to be alive in this period," he says. "Every student has all the world's available knowledge and information right there in his or her hands. It's amazing! They can research, consume, discover all parts of the world right there on their iPads."

It's easy to get swept away by Bob's passion and share his excitement and enthusiasm, whether it's how the solar system is much better understood through technology than on a piece of paper or how students light up when they realize all they can do with these tools that their parents could never have imagined. His enthusiasm is infectious, and it's clear the students tap straight into that excitement, making it their own and creating their own brilliance.

Bob's goal is to ensure his students know every device and tool inside and out, and he measures his success by what he calls the "Gimme moment." In the heat of creativity, when students are all huddled around the technology making a film or solving a problem, one student will spot a mistake that needs correcting and simply say "Gimme!," snatching the device, making the quick edit, and returning it to the huddled team in seconds so the collaboration can continue uninterrupted. "When they hit that moment, I know they've gotten it," Bob says.

As much as he loves the technology, it's MCS and the Montessori approach that truly inspire him. "I can spot an MCS student out in the community," he says. "I can tell by their confidence, how they handle themselves. MCS creates these special young people who then go out into the world with those skills." He pauses, seemingly overwhelmed by the awe of it all. "This school is creating foot soldiers of goodness who go out into the world for the betterment of society."

That's the magic. That's Mr. Bob. That's Montessori Community School.

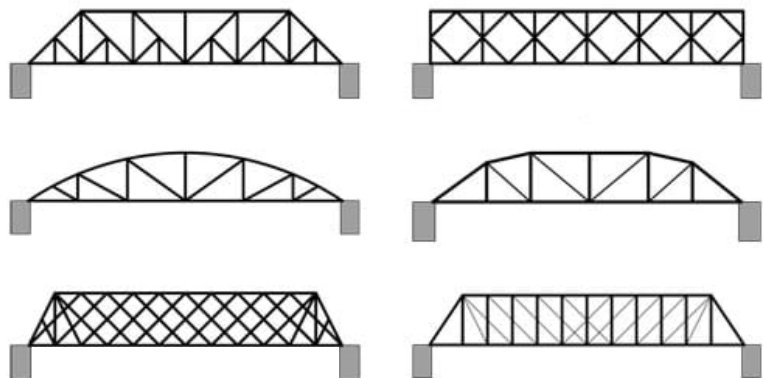
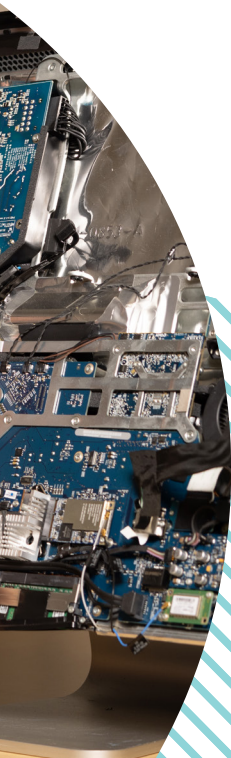

PHILANTHROPY IS A FAMILY AFFAIR - THE DELSE FAMILY IS ALL IN

When Nikki and Fred Delse became parents – to their son Evan and then to their son Ian, a couple of years later – Nikki knew their boys would attend MCS. She'd spent her preschool through third grade years at MCS, herself, and after all these years, it still defines her. Luckily, Fred knew to listen to his wife and soon found himself as dedicated to MCS as she is. Their boys' joy, love of learning, and growing confidence and character sealed the deal.

Evan graduated from MCS in 2020, heading off to Punahou with several of his classmates, while Ian is an MCS 6th grader this year, and Nikki and Fred's generosity towards MCS is as deep and wide as ever. "I doubt we're anywhere close to the biggest monetary donors," Nikki says, "but we try to help whenever we can."

That's the thing about philanthropy. Of course financial support is essential, but so is showing up, doing what you can, and modeling for your own children what it means to do your part. Nikki reminisces about the MCS Scholastic Book Fairs, which, for several years, she volunteered to staff, transforming the Music Room into a literary oasis and spending days with her two boys, opening the fair, closing at the end of the day, and perusing countless books for themselves and for their classrooms.

She laughs that her parents and Fred's parents love showing up every year for Kupuna Day, excited to be part of the boys' lives and carefully selecting items from the teachers' wish lists, knowing that the boys will benefit from their generosity. Their children's education is a family affair, with parents, grandparents, and students alike participating and helping wherever they can.



"We try to help whenever we can."

When the pandemic changed the Fun Run, the annual school fundraiser which gets families and students outside and active to raise money for the Children's Education Fund, the children were given wrist-worn pedometers to count their steps and encourage parents, grandparents, neighbors and others to donate to the cause. "When Ian told us about it, we agreed to make a pledge based on steps," Nikki laughs, not realizing the depth of Ian's devotion to the task at hand. He racked up more than 20,000 steps a day, coming in at the top of the leaderboard and logging more than a half million steps. His parents proudly paid up.

When Nikki talks about Evan and Ian, she gets a bit emotional, tearing up as she describes what MCS has given her sons. "Knowing that whatever we do as a school community results in kids who love learning and are so well prepared for the rest of the world and the rest of their lives, there's nothing more valuable," she says.

As for Ian, he's all-in for the adventures still ahead of him. "I like MCS because of the independence we have and that we're not ordered around all the time," he says. When asked about leaving MCS in the not-too-distant future, he shrugs. "I'll be sad to leave, but I'll probably go to Punahou or Mid Pacific, and I know I'm ready to embrace a new school."

Building character. Creating life-long learners. Bringing families together for the good of the children. That's what Nikki knew and what Fred discovered about MCS' mission to deliver an education for life.



GIFTS AND FUNDRAISING

SEPTEMBER 1, 2020 - AUGUST 31, 2021

GIFTS BY CATEGORY

Kupuna Day

\$1,066

MCS Annual Fund

\$71,376

Restricted Gifts

\$75,815

Grants

\$16,500

Fun Run

\$42,052

Total

\$206,809

* No Spring Fling Held in 2021 * No Montessori Magic Held in 2021

SOURCE OF GIFTS

A

Alumni

2.50%

G

Grandparents

15.10%

F

Friends

20.76%

O

Foundations &
Corporations

22.42%

S

Faculty, Staff,
& Board

11.93%

C

Current
Parents

27.30%



PHILANTHROPY AT WORK

This Annual Report of Giving is prepared by the MCS Development Department in recognition of the many generous gifts the school receives from parents, former parents, staff, faculty, alumni, and friends. The report lists all gifts received from September 1, 2020 through August 31, 2021, unless otherwise stated. It includes gifts for Give Aloha, Aloha United Way, Virtual Fun Run, year-end appeal, grants, Kupuna Day, cash donations, and matching gifts. We make every effort to ensure that listings are accurate. However, if your name was omitted or listed incorrectly, we sincerely apologize. We hope you will inform us accordingly by contacting the Development Office at (808) 522-0245 or development@montessorihawaii.org so that we may correct our records. Thank you, again, for your caring support of MCS!

Memorial and Gifts In Honor

A memorial gift to MCS can help perpetuate the values that guided a loved one's life. Gifts may also honor a person during his or her lifetime, or commemorate a significant event. These thoughtful gifts become a tribute that touches the lives of our students.

Golden Bead Circle - \$10,000+

James and Lisa Nakata
The Samuel N. and Mary Castle Foundation#

Visionary - \$5,000 - \$9,999

City and County of Honolulu
U.S. Department of Education

Scholar - \$2,500-\$4,999

BRUG Bakery Hawaii#
Keith and Polly Steiner Family Foundation#
Jennifer Oyer
Glenn and Susan Shea10+
Patrick and Patsy Tom20+

Leader - \$1,000-\$2,499

Anonymous (2)
Tom and Paula Brotherton5+
Marjie Carroll3+
James Collins and Melissa Treptow
Foodland Super Market, Ltd.#≥15+
Lance Garrison and Nicole Gesik Garrison3+

Steve Holaday10+
Joanne T. Le DDS#5+
Myong and Gyeongri Kim
Mark, Rachel, and Sara Macke15+
Chris and Amy Marvin3+
JP Morgan Chase Foundation#≥
Gary and Judith Okamoto3+
Todd Okamoto and Lorena Yamamoto
Pacific Risk Solutions#
Jeffrey Peterson and Sarah Grekin
Merle A. Ryland
Susan Siebert10+
Shigeru and Millicent Takayama

Mentor - \$500-\$999

Benjamin Ancheta, Jr. and Patricia Ancheta10+
Anonymous (2)10+
Philip and Lisa Browning10+
Andrew Currihan and Kimm Teruya
CW Associates, CPAs#
Jean Fong
Kelly and Kristie Fong3+

Buddy and Melga Gendrano5+
Jay Hanamura '963+
Zhuen He and Qihong Wang
Todd Iacovelli
John Bradley and Hope Ishii3+
Charles and Lauren Kam5+
Calbert and Cynthia Lum5+
Madhu Lundquist and
Chelsea Jackson-Lundquist
Joseph Mottl III and Sherri Tisza5+
Michael and Sara Nieling5+
Jamie Reh and Nicole Kunz-Reh
Jake and Cathy Ross3+
Tony and Valerie Schmidt5+
Kazuo and Kathy Shirakawa20+
Alexander Shor and Joan Gardner
Kevin Washington and Petrice Flowers5+
Erik and Jenny West5+

Educator - \$100-\$499

Kenneth Allison and Lisa Grant3+
AmazonSmile Foundation#3+

Educator - \$100-\$499 (cont.)

Anonymous (4)¹⁰⁺⁽¹⁾
 Gene Altman
 Kenneth and Biljana Baker
 John and Paulette Ball
 Phuong Ball⁵⁺
 Shannon Ball and Frances Gendrano⁵⁺
 Melissa Baralt
 Brady and Christine Battad⁵⁺
 Richard Borreca and June Watanabe-Borreca
 Sara Borreca
 Buddy and Nancy Bottelo⁵⁺
 Kay Burgoyne
 Matthias Busch and Tania Narvaes-Busch
 Aaron Campbell and Yuko Oshika³⁺
 James and Miho Chan¹⁰⁺
 Micah Chan '15
 Clement Ching and Jaclyn Lum⁵⁺
 Jackson Cho and June Choong
 Song and Paveenin Cho⁵⁺
 Kevin and Janyce Connelly³⁺
 Charles M. Cooke IV and Sue Cooke
 Earl and Tracy Crawford
 Frederick and Nikki Delse⁵⁺
 Ty and Jasmine Dempsey
 Gavin Doi and Mari Kishimoto Doi³⁺
 Carolyn Eaton
 John Egan and Mabel Wong⁵⁺
 Jennifer Ezekiel
 Nissim Ezekiel
 Kuolin Fung and Yinphan Tsang³⁺
 Nicolas and Sherry Gaillard⁵⁺
 Babette Galang
 Evelyn Gallagher
 Jonathan Gallagher and Nicole Altman
 Jay Grekin
 Nancy Grekin
 Dean and Debbie Gushiken⁵⁺
 James and Myra Gushiken⁵⁺
 Bonnie Hair
 Mahina Haumea
 Marion Higa
 Joanne Higashi
 Oscar Ho and Emma Hu⁵⁺
 Bernard R. Hoffman
 Dayton and Linda Holt
 James and Amy Honey
 Katsuhiko and Megumi Hoshi⁵⁺
 Sean Iida and Jennifer Shim⁵⁺
 Melvin Y. Ishii
 Island Jiu-Jitsu, LLC#
 Grant Jones and Taea Takagi-Jones '96³⁺
 James and Alison Kang³⁺
 Deb Kastner
 Paul and Joanne Kennedy⁵⁺
 Yohei and Ayako Koike
 Stephanie Komaru
 Lawrence and Mi Kyong Kwak
 Tony and Mirei Kwak
 Joshua and Stephanie Lake³⁺
 Michael Lam and Mari Kishida
 Kenneth Tuyen Le
 Steve Lee and Allison Rodden-Lee

Vincent and Julia Lee
 Richard and Georgia Lees⁵⁺
 John and Marian Leong¹⁰⁺
 Gary and Olga Levy
 Kay Lewis
 Carol Lieban
 Jeffrey Loh and Caroline Chang
 Matthew and Beatriz Loo⁵⁺
 Carol Marlow
 Christopher Martin and Kazue Takashima³⁺
 Col. and Mrs. Geoffrey Martin
 Kathryn Marvin
 Maya Maxym
 Rob and Alena McEntire
 Clarice McFadden
 Kathleen McIntyre
 Lynne G. Meyer
 Charles Miller
 Dale and Alison Miller³⁺
 Joel Miller
 Michael and Sara Miller
 Robert and Lindsay Mist
 Michael and Doris Miyasaka⁵⁺
 Lester Morehead and
 Chi-Cheng Morehead-Yang
 Ben Morgan
 Fauzia Morgan
 James and Lauren Moriarty
 Mana and Sarah Moriarty
 Rodney and Cheryl Moriyama⁵⁺
 Laura Mueller¹⁰⁺
 Music Ventures#
 Michael Nagavkar
 Dana Nakasato⁵⁺
 Rob and Suzie Neufeldt
 Mavis Nikaido⁵⁺
 Ryan Nobriga
 Ashley Nolan
 Fernando and Angela Nolan
 Dawn Ogawa
 Susan and Patrick Oshiro⁵⁺
 Bob and Carol Lee Owens⁵⁺
 Jason and Marissa Owens⁵⁺
 Dr. and Mrs. Robert G. Peters¹⁵⁺
 Ted and Catherine Pettit¹⁰⁺
 Miyoko T. Pettit-Toledo
 Platform LLC#
 George Power
 Amalia Prado
 Jasmine Pritamdasoni
 SueEllen Quick
 Iskandar Rabeendran and Monique Chyba
 Matthew Raff '99 and Hannah Raff³⁺
 Bill and Betsy Rezel⁵⁺
 Eddie and Sulia Ricote⁵⁺
 Andrew Robbins and Wendy Dela Cruz
 Sharon Ross³⁺
 Clifton and Abby Royston
 Cheryl Lynn Tanguilig Rudy
 Joe Ryan and Jeanne Miyasaka⁵⁺
 Stan and Georgette Sakumoto
 Daniel and Setsumi Saltman
 Heather Schneider

Lukas Sheild³⁺
 Sandra Shim⁵⁺
 Dr. and Mrs. Walton K. T. Shim⁵⁺
 Doug and Leila Shimokawa
 Joseph Silver and Jaslyn Silver '93
 Conrad Snover
 Junghee Sohn
 Adam Spurgat and Jacey Waterhouse¹⁰⁺
 Keith and Emily Steiner
 Ryan and Yukiko Sugamoto
 Ross and Audrey Sutherland
 Christopher and Cari Suzuki³⁺
 Rodney Suzuki
 Yoko Takahashi
 Janel Takasaki
 Michael and Rebeka Takayama⁵⁺
 Cari L. Tanabe
 Catherine A. Taschner
 Candace Tasoe
 Lelani Teruya
 The MacNaughton Group Foundation#[≥]
 Jennifer Tom '90¹⁰⁺
 Royce Tomson³⁺
 Clyde and Margo Torigoe⁵⁺
 Peggy Umetsu
 James and Robin Urso
 Calvin and Lianne Uyehara
 Dennis Uyehara⁵⁺
 Anthony Vericella
 Jason Vigil and Tammy Chang
 Tracy Wall
 Jeff and Maryellen Walters
 Benjamin and Ashley Wang
 Mark Watford
 Peter and Denise Webb
 David and Laura White¹⁵⁺
 Geoffrey and Emi Wooden
 David Woodward and Dara Chun-Woodward
 Mysee Xiong
 Mr. and Mrs. Clyde Yamamoto³⁺
 Logan and Hyesook Yamamoto
 David Yogi, Jr.
 Thomas and Bunnie Yoneyama
 YourCause, LLC Trustee for New York Life#^{≥3+}

Supporter - up to \$99

Gal Amimoto
 Maja Andreevska
 Anonymous (2)⁵⁺³⁺
 Maya Aquino
 Francis Arakaki
 Lynnette Atkins
 Juan Becerra
 Chris Bednarek and Jaclyn Hawse
 John Bellamy
 Laurie Bienfang
 Andrea Blackwell
 Caroline Blackwell
 Catherine Blackwell
 Leslie Blackwell
 Rachel Blackwell
 Cindy Blanz
 Noah and Shana Branscom⁵⁺

Supporter - up to \$99 (cont.)

Sandra Brewer
Joey and Sharon Brunson
Naydeen Buente
Merissa Bunton
Haley Chaffin
Joe and Elena Chan¹⁰⁺
Ms. Kazuko Chan⁵⁺
Andrea Chavez
Spencer and Connie Ching
Milton and LiAnn Choy⁵⁺
Candice Chun
James and Molly Cooper⁵⁺
Brad Damron
Timothy Danae
Ruth A. Degand
Nickole Dixson
Andrew Djordjev
Robert Dobrzynski
Gary and Mary Doi
Michelle Dolezal
Tracy Dowling
Solita Dytioco
Joshua and Brenda Ferrulli
Kyle and Raylene Gieg
Karen Goertz
Sharon Goertz
Samaya Gorham '11
Andrew Greene and Jan Brunson
Susan Greene
Jeremy Grekin
Rebecca Grekin
Geeta Gupta
Bryan J. Gushiken
Joel Gushikuma
Annie Hallstein³⁺
Sheree Hashimoto
John Hawse
Shannon Heaven
Bradley and Priscilla Hee⁵⁺
Beth Heikkila
Michael Herr
Walter and Amy Higashi
Blyth Hirata
David and Frances Hisashima
Evonne Ho
Alanna Hobbs
Jamie Hu
Yun C. Hu and Qi Jun Peng
Lynne Hulsebos
Melanie Ide
Shuji Igushi
Deborah Iida
Faith Ishii
Joy L. Ishii
Michiko Isoda
Mihajlo Jankoski
Jennifer Johnson
Steve and Lois Kakuni⁵⁺
Jenavi Kawamura
Abhi and Roshni Koli
Suzana Kominovska
Jerold and Lori Kouchi

Beth Kreitzer
Gregory J. Kurras
Jenny Kwak
Tedd and Danelle Landgraf
Allyna Lee
Diane Lee
Jimmy Lee
Frank and Pilar Leto
Garett and Sheri Lew
John and Courtney Lin⁵⁺
Jason Louie
Sharon Maekawa
Barry and Wendi Major
Gabby Makuakane
Adit Mane
Richard and Yayoi Marshall
Nicholas Marvin
Mr. and Mrs. Roy A. Masatsugu
Ken and Pauline Mashima
Carol Maxym
Eda Maxym
Kala Maxym
Scott McDonald and Yuen Liang
Evan Miller³⁺
Sally M. Mist
Crystal Miyamoto
David K. Miyasaka⁵⁺
Elizabeth Mossman
Maya Nagavkar
Signe Nakayama
Jim and Kay Nieling
Hans Nielsen
Susan K. Oliva
Cheryl Peck
Pegasus Physical Therapy Solutions
Michal Penek
Bob and Susana Peterson
Lisa Peterson
Daniela Petrova-Manoilova
Trinh Pham
Adam Poe
Beverly Quon
Carol Raff
Yuri Rhoden
Estelle Rodgers
Mimi Rogers
Alyssa Russell
Arthur Sarkissian
Harold and Linda Sato⁵⁺
Christopher Shim
Cindy Shyne¹⁵⁺
Marnie Simon
Jenny Sipe
Haleigh Sivavec
Jonathan Sizemore
Sarah Sloan
Starr W. Snead⁵⁺
Sandra Souza Dias
Linda Takai
Lon Tanigawa
Gary and Candace Tasoe
Kelsey Tasoe
Kenneth and Vivian Tilton

Zan Timtim
Jeremy Trueblood
Predrag Uncanin and Natasha Tom-Uncanin
Patti Urso
Cenon and Tsuruko Usita⁵⁺
Danni Vaiceliunas
Joy Vink
Aleli Vinoya
Suzie Wallace
Melissa Wetzel
Christopher and Ayami Won
Bruce and Charmain Wong
Deneen Wong⁵⁺
Micah and Namie Wong
Noah and Caycie Wong
Dr. and Mrs. Vince Yamashiroya
Jaryd Yee

In Memory of Jerry Mueller

Lindsay Mist
Mr. and Mrs. Richard Marshall
Mr. John Egan and Dr. Mabel Wong
Mr. and Mrs. Eddie Ricote
Mr. and Mrs. Tom Brotherton
Mrs. Elisabeth Browning and
Dr. Philip Browning
Ms. Joanne Higashi
Ms. Samaya Gorham '11
Ms. Danni Vaiceliunas

In Memory of Thomas W Brotherton Sr.

Ms. Carol Marlow

In Honor of James Takeshi Ng

Mr. and Mrs. Harold S. Sato

In Honor of Kylie Nakamura

Mr. Lester Nakamura

In Honor of Susan Siebert & Jerry Mueller

Mr. and Mrs. Benjamin Bottelo

In Memory of Matthew Foster

Mr. and Mrs. Glenn Shea

In Memory of Paul Bienfang

Mr. and Mrs. Glenn Shea



Education for Life

KEY: ≥ = Matching Gift

= Foundation/Corporation Giving

Years of Consecutive Giving (3+ only if given in last 3 years: 9/17-8/20): 20+/15+/10+/5+/3+

CHRIS MARVIN - CONTINUING TO SERVE

Husband. Father. Combat-wounded veteran. Community leader.

Heroes come in all types, and Chris Marvin is one of those heroes with lots of words describing him. Chris, one of MCS' unsung heroes, is a member of the MCS Board of Trustees and dedicated supporter of the school.

Parents, teachers, and friends have gone above and beyond the call of duty in service to our children during Covid, stepping up again and again every time we needed it. And people like Chris have been there, too, making powerful contributions and difficult decisions to keep our school thriving as we weathered this long pandemic storm.



Serving others comes naturally for Chris. A U.S. Army veteran and Black Hawk helicopter pilot, Chris was wounded in combat Afghanistan. You'd never know that though from his modest, humble demeanor and quiet but impactful contributions within our school community.

For over five years, Chris' expertise in strategy, communications, and collaborative leadership helped ground us as we created an inclusive environment that nurtures the spirit of the child and leads them to independence. It's clear Chris knows what he's doing. We can see it in his two girls, Claire and Emma, MCS Upper Elementary students.

"Not only do I appreciate how innovative Chris is, but he's also very mindful, ensuring that we never stray from our Montessori mission," says Head of School Marjie Carroll. "He has an incredible gift, pulling from his diverse experience in the military, nonprofits, and as a consultant for veterans, military families, policy development, public relations, and communication."

Dr. Maria Montessori once said, "Averting war is the work of politicians; establishing peace is the work of education." Chris' days serving his country and fighting for our freedom may have ended, but he continues to fight for peace through education at MCS. Everyday heroes can be found in every school across our island. We're just glad that we don't have to look very far.

Board of Trustees 2020-2021



President
Matthew Raff

Vice President
Todd Iacovelli

Secretary
Catherine Taschner

Treasurer
Todd Okamoto

Head of School
Marjie Carroll

Paula Brotherton
Lisa Browning
Kay Burgoyne

Kirra Downing
Fran Gendrano
Jay Hanamura

Chris Marvin
Todd Okamoto
Sherri Tisza



Our 48-year history provides us the privilege of welcoming a second generation of learners to MCS.
Listed below are the legacy families enrolled during 2020-2021 school year.

*Designates MCS alumnus.

Jack Avery (Preschool & Kindergarten) and Madison Avery (Preschool & Kindergarten)
Ryan* and Melissa Avery

Kenzo Battad (Preschool & Kindergarten) and Kaya Battad (Upper Elementary)
Brady and Christine (Oshio*) Battad

Layla Borreca (Preschool & Kindergarten)
Nicholas* and Sara Borreca

Cayla Ching (Preschool & Kindergarten) and Carly Ching (Lower Elementary)
Clement Ching and Jaclyn Lum*

Ian "Kai" Delse (Upper Elementary)
Frederick and Nikki (Torigoe*) Delse

Phineas Jones (Two-Year-Old) and Orion Jones (Preschool & Kindergarten)
Grant Jones and Taea Takagi-Jones '96*

Emily Mist (Preschool & Kindergarten)
Robert McKibbin* and Lindsay Mist

Kylie Nakamura (Lower Elementary)
Gavin* and Colleen Nakamura

Caleb Owens (Preschool & Kindergarten)
Jason* and Marissa Owens

Ava Quinlan (Upper Elementary)
Michael Quinlan and Allison (Shea*) Quinlan

Lionel Raff (Preschool & Kindergarten)
Matt '99* and Hannah Raff

Amaia Shelton (Preschool & Kindergarten)
Solomon and Dara (Chung*) Shelton

Sallena Takagi (Two-Year-Old)
Brennan '97* and Molly Takagi

Enzo Yee (Preschool & Kindergarten)
Aaron Yee and Lisa Chen*



ALUMNI FEATURE - YOH KAWANAMI '91

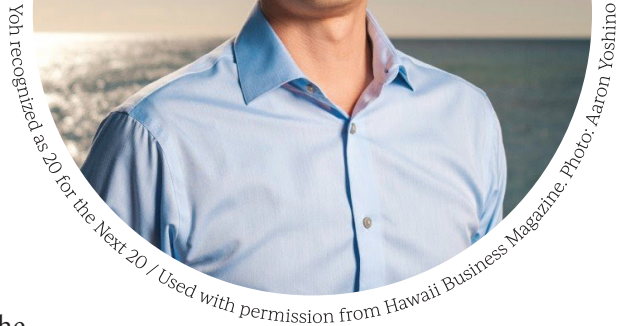

“The goal of early childhood education should be to activate the child’s own natural desire to learn.” - Maria Montessori

Yoh Kawanami attended MCS for just one year, but his experience at the school has had a lasting impact on his life. “MCS re-taught me the basics of how to study and enjoy learning,” shared Yoh.

Born in Guam and graduating in 1991 from MCS, Yoh went on to graduate from Mid-Pacific Institute in 1997. He then graduated from the University of Washington with a B.S. in Aeronautics & Astronautics, and a Master’s Degree in Engineering Management from Duke University. Yoh is now the Director of Customer Energy Resources-Operations at Hawaiian Electric Company. He is responsible for the implementation of demand response programs to enhance grid reliability and integration of additional renewable energy. He also serves as the Regional Co-Chair for the U.S. Japan Council.



Providing an “Education for Life” is not just our motto, it is who we are at Montessori Community School, and it has had a lasting impact on Yoh, serving on multiple boards and volunteering for various non-profit organizations focusing on education. “With its small school environment with 100% attention from multiple teachers, MCS really helped me level set on how to communicate with individuals, groups, and audience. I appreciate the direct training I received at MCS. I owe my successes to MCS for not giving up on me,” said Yoh.

Yoh and the Under40 Hawaii Summit planning committee for the U.S.-Japan Council: (L-R) Lea Okudara, John Rankin, Lynn Miyahira, Nicole Velasco, Yoh Kawanami, and Kim Haruki.



stay

connected!

Our alumni are an integral part of the life and continued success of MCS. Our Development Department is here to build meaningful relationships and provide resources and engaging opportunities necessary to strengthen and uphold positive connections for our alumni, students, parents, and friends.

Do you have an update that you would like to share with your MCS family? Marriages, birth announcements, job promotions, academic achievements, etc. are all things to be celebrated, and we’d love to hear from you! Please email development@montessorihawaii.org with your news.



JERRY MUELLER A LIFELONG MONTESSORI TEACHER & MORE

As Montessori Community School prepares for its 50th Anniversary next year, it is especially appropriate that we honor the late Jerry Mueller, beloved teacher and colleague, who spent his entire educational career at our school. Jerry's 43 years of service to MCS is a testimony to his caring spirit, his strength of character, and his wealth of knowledge as a teacher, parent, colleague, and member of the Board of Trustees. Jerry strongly believed in MCS' mission to offer an authentic Montessori learning experience. In 2018, he established the Jerry Mueller Montessori Teacher Training Fund to ensure that future MCS teachers could complete their Montessori certification. His fund has already helped two teachers become certified, and a third teacher is currently attending certification classes. Through the years, Jerry left his imprint on the hearts and minds of hundreds of children who entered our doors as students and left as proud alumni. His lessons helped lay a foundation for our children while fostering a spirit of commitment to bettering our world.

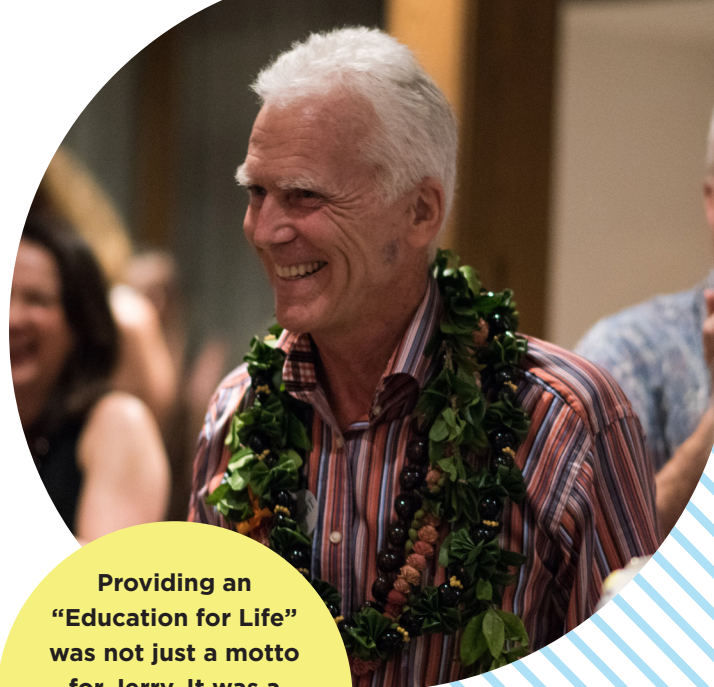

**Providing an
"Education for Life"
was not just a motto
for Jerry. It was a
lifelong dedication
to teaching and to
bettering our world.**





CONGRATULATIONS CLASS OF 2021

The MCS community celebrated the Class of 2021 (from left to right: Haġkan, Jason, Owen, Estella, and Amory) with a small gathering on May 28, 2021. There was a sense of normalcy as immediate families of the graduating class, Upper Elementary students, and 3rd grade students participated in the graduation ceremony following MCS' health and wellbeing guidelines.

There was a great deal of pride in our accomplished students who remained resilient during a challenging school year. In The Montessori Method, Dr. Montessori said that, "A room in which all the children move about usefully, intelligently, and voluntarily, without committing any rough or rude act, would seem to me a classroom very well disciplined indeed." This graduating class was truly a learning community of children committed to excellence.

A Special Thank You and Farewell

MCS extends a warm Mahalo to Lisa Browning, Michelle Aczon, and Audrey Sutherland for their very good and important work serving the children and families of MCS.



Lisa Browning

"Mrs. Browning" to her students, brought learning to life in Room 2 with joy, patience, intelligence, and steadfastness as a Montessori Lower Elementary teacher. She has had a lifelong impact on the lives of many children, parents, and colleagues, and we are so very grateful that she chose our community in which to develop her career.

MCS Class of 2020	Applied	Accepted	Attending
Iolani School	3	3	0
La Pietra	1	1	1
Mid-Pacific Institute	3	3	0
Punahou School	4	4	4
SEEQS <small>(The School for Examining Essential Questions for Sustainability)</small>	3	2, 1WL	0



Michelle Aczon

"Ms. Michelle" has been part of the MCS elementary music program starting in the late 1990's, then taking a break, and returning in 2019 to provide weekly music lessons, as well as winter and spring musical productions, that brought great fun and memorable moments to her students, families, and staff.



Audrey Sutherland

"Ms. Audrey" has worked as an assistant to Ms. Kay in the Terrace classroom since 2018 and was responsible for organizing materials, helping to guide students through self-directed activities, and creating a welcoming and purposeful learning environment.



Montessori Community School
1239 Nehoa Street
Honolulu, HI 96822-3071
www.montessorihawaii.org



Education for Life

GIVE BEYOND YOUR YEARS

Members of the Montessori Legacy Society are among Montessori Community School's most important partners. Gifts that qualify for the Montessori Legacy Society create a legacy that will shape the future of MCS and its students for generations to come.

With your gift, MCS invites you to become a member of the Montessori Legacy Society. If you have been so generous as to include a bequest to MCS as part of your estate plan, please let us know, as we wish to acknowledge your gift and welcome you to the Society.

You will join a community of special people whose commitment to excellence in Montessori education will secure the future of MCS students, programs and operations for the future. Please call (808) 522-0245 or email development@montessorihawaii.org if you would like to learn more.

Thank you for your generous support!